

NOTE: 580-00075 BED RAILS SHOWN.
OTHER CONFIGURATIONS WILL VARY SLIGHTLY,
BUT WILL NOT AFFECT ASSEMBLY.

ATTENTION READ ALL INSTRUCTIONS AND UNDERSTAND ALL WARNINGS BEFORE INSTALLING OR USING THIS PRODUCT.



DANGER OF INJURY
TEAM LIFT IS REQUIRED FOR INSTALLATION OF THIS PRODUCT.
MOVING PARTS IN THIS ASSEMBLY CAN CAUSE INJURY.



NOTES

- USE SAFETY GLASSES WHEN USING TOOLS OR WORKING UNDER VEHICLE.
- PERFORM ALL WORK ON DRY LEVEL GROUND.
- INSURE VEHICLE'S PARKING BREAK IS ENGAGED AND WHEELS ARE CHOCKED.
- DUE TO THE SIZE AND WEIGHT OF PRODUCTS MORE THAN ONE PERSON IS REQUIRED FOR LIFTING AND INSTALLING OF THIS PRODUCT.
- DO NOT OVER TIGHTEN HARDWARE.

TOOLS REQUIRED

	SAFETY GLASSES		MALLOT/ HAMMER		RATCHET & SOCKET SET
	TAPE MEASURE		DRILL/ DRIVER		WRENCH SET
	FELT TIP PEN		DRILL BIT SET		CLAMPS

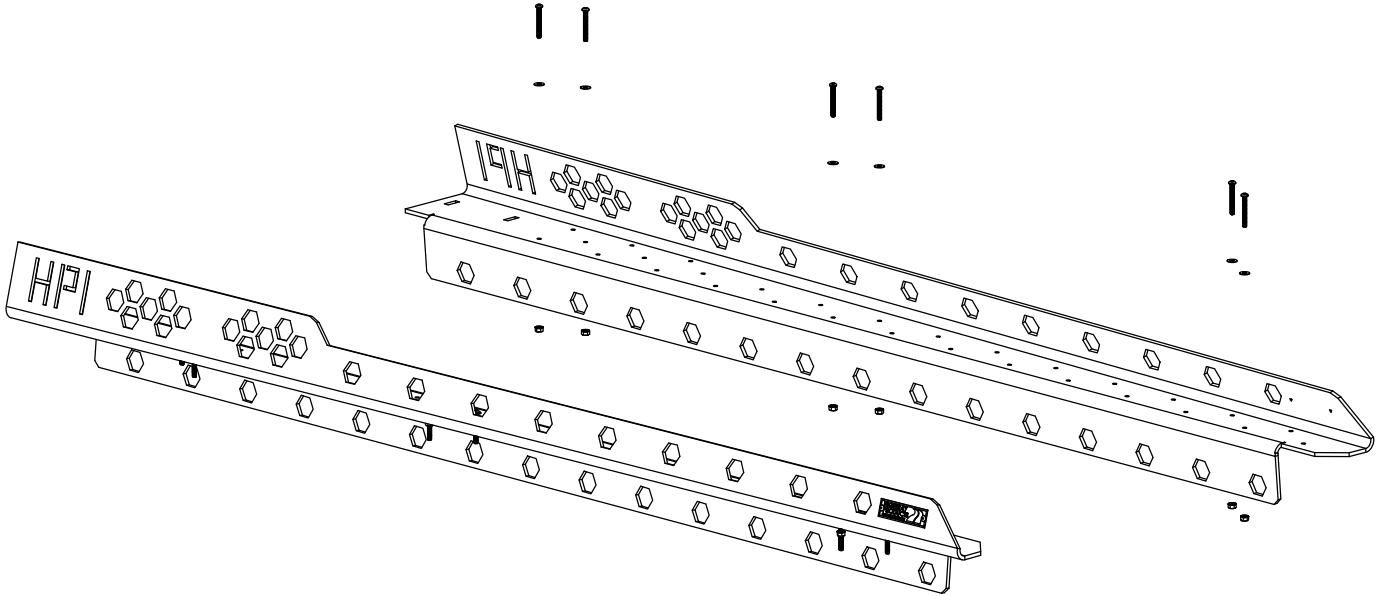

NOTE: TAKE INVENTORY OF ALL PROVIDED PARTS PRIOR TO ASSEMBLY.

PROVIDED PARTS

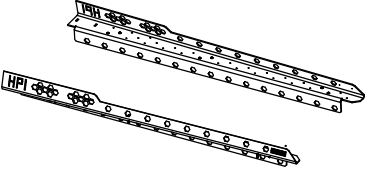
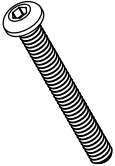
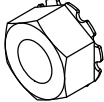
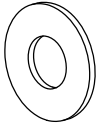
ITEM	DESCRIPTION	QTY
	BED RAILS	1
	1/4"-20x2" ALLEN HEAD BUTTON SCREW PART# 030-10010	12
	1/4"-20 STAR LOCK NUT PART# 030-10027	12
	1/4" FLAT WASHER PART# 030-15018	12



STEP 1

PLACE BED RAILS ONTO TRUCK BED AND DRILL THUR PROVIED HOLES IN BED RAIL AS SHOWN IN FIGURE 1.

NOTE: WHEN DRILLING INTO TRUCK BED, MAKE SURE THAT FASTENERS WILL BE THRU METAL AND NOT JUST THRU THE BED PLASTIC CAP WHICH IS COMMON ON NEW STYLE TRUCKS.

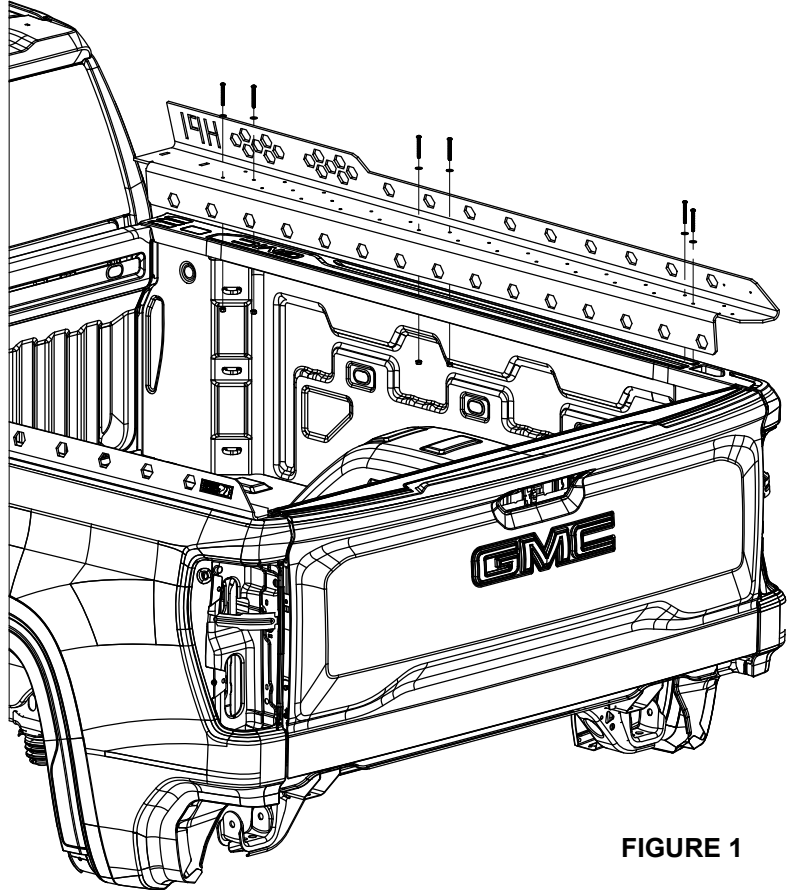

FIGURE 1

WASHER SS 1/4" FLAT SAE
SCREW SS 1/4"-20X2" ALLEN HEAD

BED RAIL

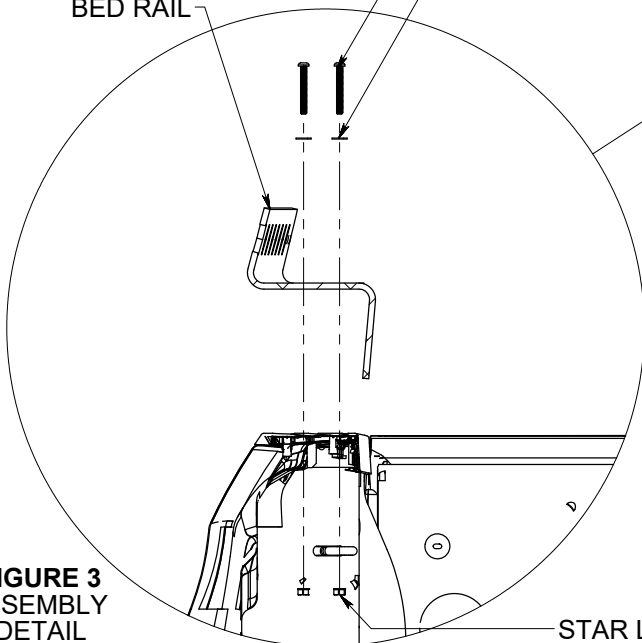

FIGURE 3
ASSEMBLY
DETAIL

STAR LOCK NUT

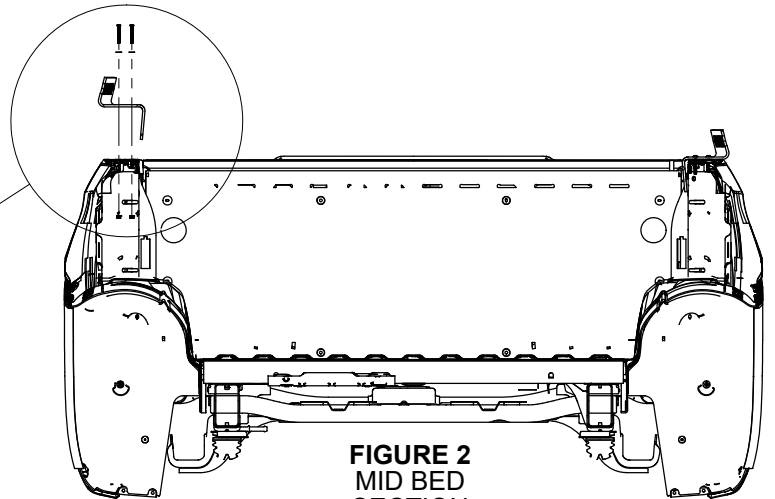

FIGURE 2
MID BED
SECTION

STEP 2

ASSEMBLE FASTENERS AS SHOWN AND ENSURE FASTENERS ARE FULLY SECURE. DO NOT OVER TIGHTEN HARDWARE.